

USER'S MANUAL - *Magnetic compass for navigation RIVIERA type WHITE STAR 6"*

Dear Customer,

in thanking you for your preference and trust in our products, we wish to inform you that this marine magnetic compass has been designed and built to perfection in the RIVIERA srl factory in Genoa.

After manual assembly, it was subjected to tests and quality controls in accordance with the requirements of the Italian shipping register, RINA. It is made with materials that have proven to guarantee its functioning aboard boats for many years.

Keep this manual together with the on-board documents.

GENERAL FEATURES

Apparent diameter 6" (130 mm o 150 mm)

Mounting: binnacle or flush

Dial gradation 2° or 5°

Dial colors: black

Front or rear reading

LED lighting 24V (12V on request),

blue color as standard

Anti-glare screen

Internal gimbal suspension

Built-in manual compensation

3 years warranty

100% repairable

CERTIFICATIONS

The MED Directive 2014/90 / EU (and its subsequent amendments) covers the main equipment and materials that are intended to be used on board seagoing (non-military) vessels.

The distinctive marking for these products is the "Wheelmark". The technical rules applicable to marine equipment come from three sources: the Convention for the Safety of Life at Sea (SOLAS), the Resolutions of the International Maritime Organization (IMO) and the European Standards (EN).

The RIVIERA class B compasses of the WHITE STAR type (with the exception of the B6W6, BW6 e BW5 models) have been certified in accordance with MED 2014/90 EU.

RIVIERA WHITE STAR: This Type of compasses is Certificated as lifeboats and rescue boats equipment.

Any MED certificate for the single compass must be requested when ordering and cannot be issued after supply.

INSTALLATION

The way to install a Riviera magnetic compass differs depending on the model.

Please read the following carefully.

To install the purchased compass on board, in addition to the specific operations linked to the model and indicated in the attachment, keep in mind the following:

- 1) Choose the installation site so that it is as far away as possible from magnetic fields, or other moving ferrous masses.
- 2) Before connecting the two LED lighting wires to the on-board system, check the correspondence of the network voltage.
- 3) At the end of the installation, have the compensation of the RIVIERA compass performed by an authorized professional.

BINNACLE MOUNT MODELS

According to the models, follow the instructions contained:

For the compass B6W6 & B6W5 - ANNEX A

for the compass B6W4 - ANNEX E

FLUSH MOUNT MODELS

For the models that must be mounted flush by cutting a boat wall (B6W3), refer to the on board mounting scheme contained in the box.



USER'S MANUAL - *Magnetic compass for navigation RIVIERA type WHITE STAR 6"*

COMPENSATION & MAINTENANCE

Riviera compasses are calibrated for zone A. On request, when ordering, they can be calibrated for zone B or C.

After installation on board, compass compensation must be carried out by a professional authorized by the local Maritime Authority who will operate on the screws accessible through the lower transverse holes.

Clean the Riviera compass with a soft cloth moistened with fresh water.

REPAIR

For the purposes of forfeiture of the warranty terms and for your safety, any repairs may be carried out only and exclusively by the manufacturer. In case of need, please contact RIVIERA Srl - info@rivieragenova.com

PACKAGING

The RIVIERA WHITE STAR compass is delivered in protective packaging suitable for international shipping

1 box dim. 23,5x23,5x25 cm total weight Kgs. 3,3 - 4

LIQUID

The liquid contained in the RIVIERA compasses is stable in the temperature range from -30 ° to + 60 ° C. In this range there should be no bubbles, this is guaranteed by an elastic membrane that compensates for volumetric variations. The liquid is Shell SolD / 70 (petroleum).



ATTENTION: Never unscrew the filler plugs and screws for any reason. The only screws to adjust are those of the compensators (with a non-magnetic screwdriver). When the cut of the compensator screws is in the horizontal position the compensation is neutral, bringing the cut in the vertical position is maximum.

Certificate of Warranty



This document is valid as a guarantee certificate.

The company RIVIERA srl Genoa guarantees that its compasses are built in a workmanlike manner and that they are free from manufacturing and material defects.

If within 36 months from the date of manufacture (stamped on the flange) the product should show malfunctions, the company will repair or replace it, at its sole discretion, free of charge.

The warranty is void if the damage is caused by improper use, incorrect installation or accidental breakage.

The warranty does not cover any costs deriving from assembly or disassembly of the products, transport of the same and expenses for technical personnel, even if attributable to manufacturing defects.

In the event of a dispute, the competent court is the court of Genoa.

ALLEGATO A (ATTACHMENT A) - Istruzioni - (Instructions) BW2-BW4-BW5-BW6 B6W5-B6W6

Seguire scrupolosamente le indicazioni seguenti:

1. Per sollevare la bussola dalla sua chiesuola allentare le viti laterali della calotta.
2. Togliere la calotta antiriflesso.
3. Svitare **solo le due viti a taglio**. Per non danneggiare la bussola le viti a croce non devono essere allentate per nessun motivo.
4. Riavvitare le viti laterali della calotta, con queste, fare leva verso l'alto per estrarre la bussola dalla sua chiesuola.
5. Fissare la chiesuola all'imbarcazione utilizzando i 4 fori di fissaggio e le viti in dotazione.
6. Reinserire la bussola all'interno della chiesuola e fissarla tramite le due viti a taglio.
7. **Attenzione: i due elementi a croce sono i supporti dei magneti di compensazione e NON devono essere mai toccati da persone inesperte.**

Strictly follow the instructions below:

1. To lift the compass from its binnacle, loosen the screws on the side of the hood.
2. Remove the anti-reflective hood.
3. Unscrew **only the two slotted screws**. In order not to damage the compass, the Phillips screws must not be loosened for any reason.
4. Re-tighten the lateral screws of the cover, with these, lever upwards to extract the compass from its binnacle.
5. Secure the binnacle to the boat using the 4 fixing holes and screws provided.
6. Reinsert the compass inside the binnacle and fix it with the two slotted screws.
7. **Attention: the two cross elements are the supports of the compensation magnets and must NEVER be touched by inexperienced people.**

Suivez strictement les instructions ci-dessous :

1. Pour soulever le compas de son habitacle, desserrez les vis sur le côté du capot.
2. Retirez le capot antireflet.
3. **Dévissez uniquement les deux vis fendues.** Afin de ne pas endommager le compas, les vis cruciformes ne doivent en aucun cas être desserrées.
4. Resserrer les vis latérales du couvercle, avec celles-ci, lever vers le haut pour extraire le compas de son habitacle.
5. Fixez l'habitacle au bateau à l'aide des 4 trous de fixation et des vis fournis.
6. Réinsérez le compas à l'intérieur de l'habitacle et fixez-la avec les deux vis à fente.
7. **Attention : les deux éléments transversaux sont les supports des aimants de compensation et ne doivent JAMAIS être touchés par des professionnelles.**

Siga estrictamente las siguientes instrucciones:

1. Para levantar la brújula de su bitácora, afloje los tornillos en el lateral de la capota.
2. Retire la capota antirreflejante.
3. **Desatornille solo los dos tornillos ranurados.** Para no dañar la brújula, los tornillos Phillips no deben aflojarse por ningún motivo.
4. Vuelva a apretar los tornillos laterales de la tapa, con estos, haga palanca hacia arriba para extraer el casquillo de su bitácora.
5. Fije la bitácora a la embarcación utilizando los 4 orificios de fijación y los tornillos proporcionados.
6. Vuelva a insertar la brújula dentro de la bitácora y fíjelo con los dos tornillos ranurados.
7. **Atención: los dos elementos transversales son los soportes de los imanes de compensación y NUNCA deben ser tocados por personas inexpertas.**

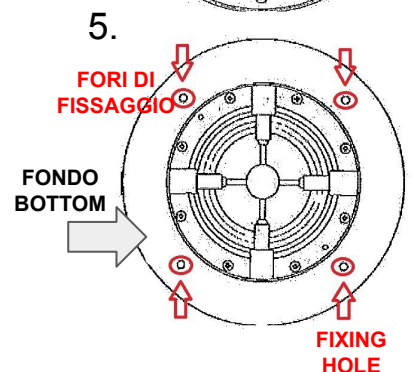
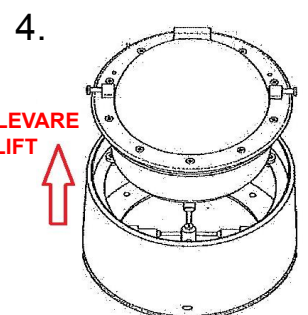
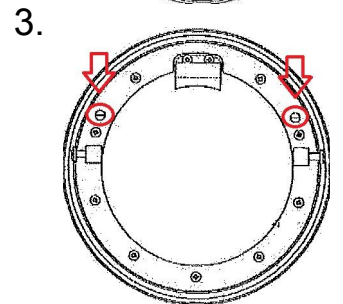
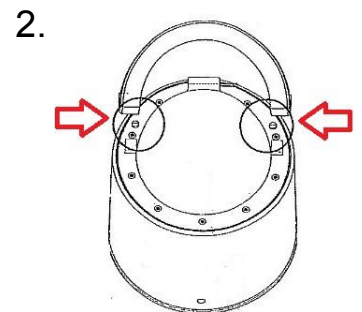
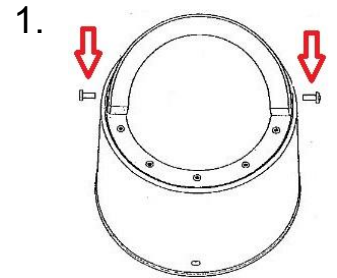

ALLEGATO A (ATTACHMENT A) - Istruzioni - (Instructions) BW2-BW4-BW5-BW6 B6W5-B6W6

Befolgen Sie strikt die folgenden Anweisungen:

1. Um den Magnetkompass aus seiner Halterung zu heben, lösen Sie die Schrauben an der Seite der Haube
2. Entfernen Sie die Antireflexhaube
3. **Lösen Sie nur die beiden Schlitzschrauben.** Um den Magnetkompass nicht zu beschädigen, dürfen die Kreuzschlitzschrauben keinesfalls gelöst werden.
4. Ziehen Sie die seitlichen Schrauben der Abdeckung wieder fest und hebeln Sie diese nach oben, um den Magnetkompass aus seinem Gehäuse zu ziehen.
5. Befestigen Sie die Binnacle mit den 4 mitgelieferten Befestigungslöchern und Schrauben am Boot.
6. Setzen Sie den Kompass wieder in das Gehäuse ein und befestigen Sie sie mit den beiden Schlitzschrauben.
7. **Achtung: Die beiden Querelemente sind die Träger der Kompensationsmagnete und dürfen NIEMALS von unerfahrenen Personen berührt werden.**

Строго следуйте приведенным ниже инструкциям:

1. Чтобы снять магнитный компас с нактоуза, ослабьте винты сбоку бленды.
2. Снимите антибликовый колпак.
3. **Отвинтите только два винта со шлицем.** Чтобы не повредить магнитный компас, винты с крестообразным шлицем ни в коем случае нельзя ослаблять.
4. Снова затяните боковые винты крышки, подняв их рычагом вверх, чтобы извлечь магнитный компас из нактоуза.
5. Прикрепите нактоуз к лодке с помощью 4 крепежных отверстий и винтов, входящих в комплект.
6. Снова вставьте компас в нактоуз и закрепите его двумя винтами со шлицем.
7. **Внимание: два поперечных элемента являются опорами компенсационных магнитов и НИКОГДА не должны прикасаться к ним неопытными людьми.**

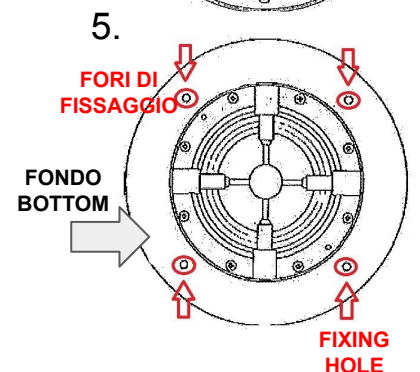
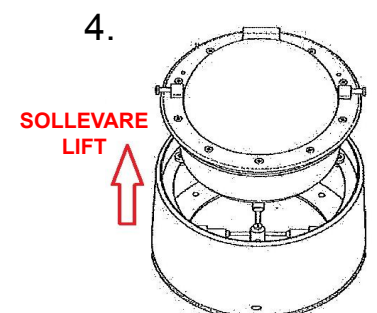
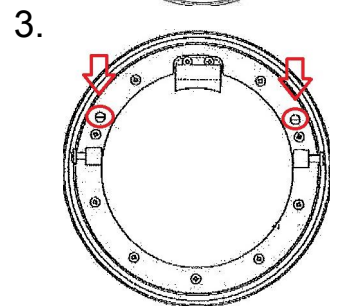
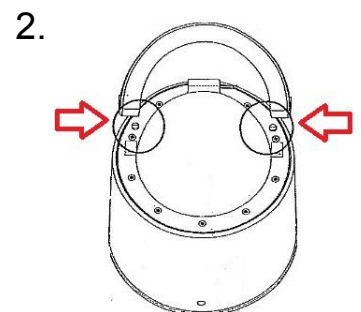
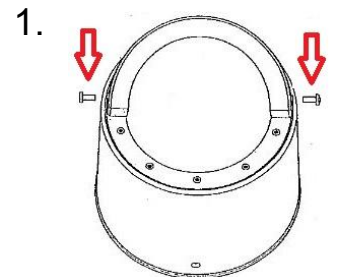

ALLEGATO E (ATTACHMENT E) - Istruzioni - (Instructions) B6W4

Seguire scrupolosamente le indicazioni seguenti:

1. Per sollevare la bussola dalla sua chiesuola **svitare solo le 4 viti a taglio**. Per non danneggiare la bussola le viti a croce non devono essere allentate per nessun motivo.
2. Sollevare la bussola dalla sua chiesuola.
3. Fissare la chiesuola all'imbarcazione utilizzando i 4 fori di fissaggio e le viti in dotazione.
4. Reinsere la bussola all'interno della chiesuola e fissarla tramite le 4 viti a taglio.

Strictly follow the instructions below:

1. To lift the compass from its binnacle **unscrew only the 4 slotted screws**. In order not to damage the compass, the Phillips screws must not be loosened for any reason.
2. Lift the compass from its binnacle.
3. Secure the binnacle to the boat using the 4 fixing holes and screws provided.
4. Reinsert the compass inside the binnacle and fix it with the 4 slotted screws.

Suivez strictement les instructions ci-dessous :

1. Pour soulever le compas de son habitacle, **dévissez uniquement les 4 vis fendues**. Afin de ne pas endommager le compas, les vis cruciformes ne doivent en aucun cas être desserrées.
2. Soulever le compas de son habitacle.
3. Fixez l'habitacle au bateau à l'aide des 4 trous de fixation et des vis fournis.
4. Réinsérez le compas à l'intérieur de l'habitacle et fixez-la avec les 4 vis à fente.

Siga estrictamente las siguientes instrucciones:

1. Para levantar la brújula de su bitácora, **desatornille solo los 4 tornillos ranurados**. Para no dañar la brújula, los tornillos Phillips no deben aflojarse por ningún motivo.
2. Levantar la brújula de su bitácora.
3. Fije la bitácora a la embarcación utilizando los 4 orificios de fijación y los tornillos proporcionados.
4. Vuelva a insertar la brújula dentro de la bitácora y fíjelo con los 4 tornillos ranurados.

Befolgen Sie strikt die folgenden Anweisungen:

1. Um den Magnetkompass aus seiner Halterung zu heben, **lösen Sie nur die 4 Schlitzschrauben**. Um den Magnetkompass nicht zu beschädigen, dürfen die Kreuzschlitzschrauben keinesfalls gelöst werden.
2. Magnetkompass aus seiner Halterung zu heben.
3. Befestigen Sie die Binnacle mit den 4 mitgelieferten Befestigungslöchern und Schrauben am Boot.
4. Setzen Sie den Kompass wieder in das Gehäuse ein und befestigen Sie sie mit den 4 Schlitzschrauben.
5. **Achtung: Die beiden Querelemente sind die Träger der Kompensationsmagnete und dürfen NIEMALS von unerfahrenen Personen berührt werden.**

Строго следуйте приведенным ниже инструкциям:

1. Чтобы снять магнитный компас с нактоуза, **Отвинтите только 4 винта со шлицем**. Чтобы не повредить магнитный компас, винты с крестообразным шлицем ни в коем случае нельзя ослаблять.
2. снять магнитный компас с нактоуза.
3. Прикрепите нактоуз к лодке с помощью 4 крепежных отверстий и винтов, входящих в комплект.
4. Снова вставьте компас в нактоуз и закрепите его 4 винтами со шлицем.

1.

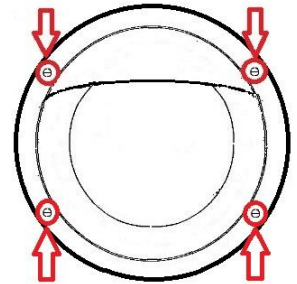

2.

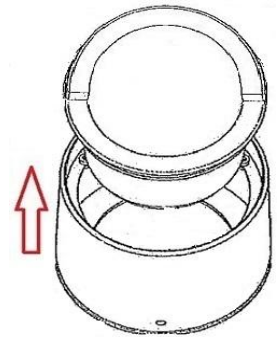

3.



VISTA DALL'ALTO
VIEW FROM TOP

4.

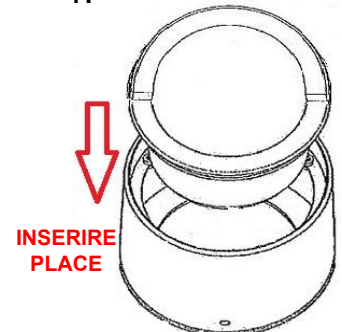

INSERIRE
PLACE

SCHEMA DI FORATURA (ON BOARD MOUNTING SCHEME) tipo WHITE STAR B6W3

